

Pneumatic Flange Mounted

ONE PIECE DESIGN

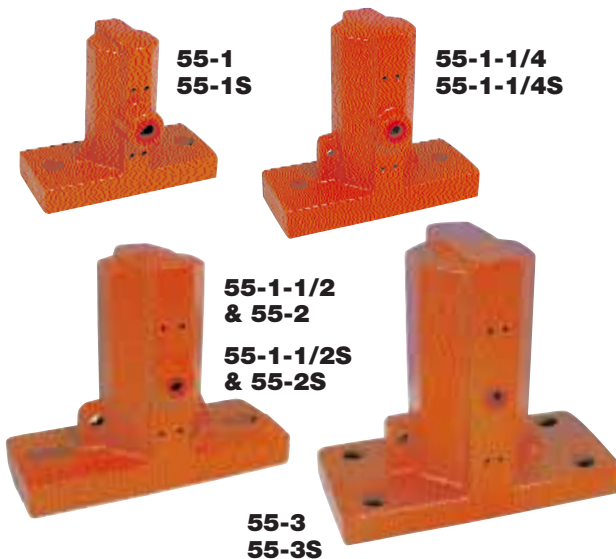

ALL STEEL MODELS

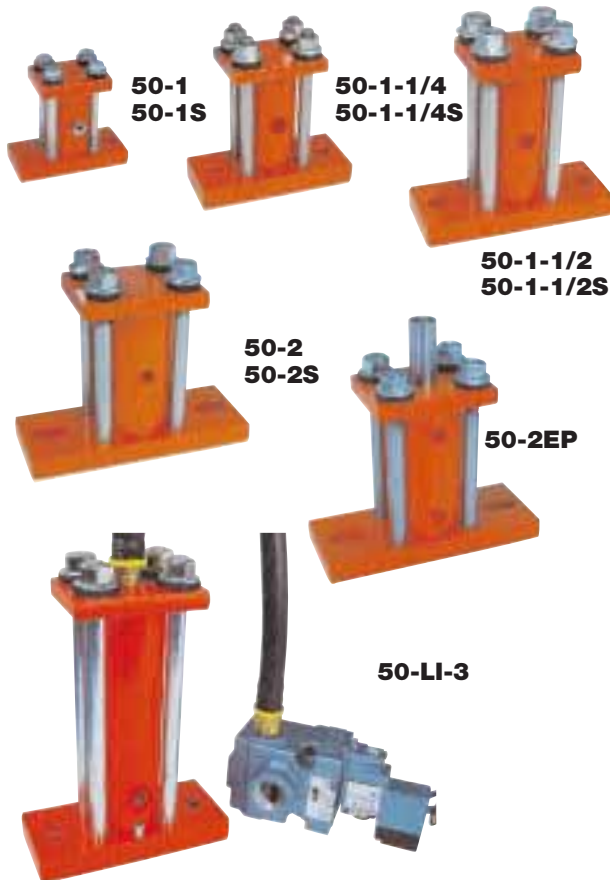

ONE PIECE DESIGN

- **LOW COST**
- **ONLY 3 PARTS**

VIBCO is the only company featuring both the One Piece Design and the All Steel Models. The one piece housing makes the unit low in cost but still maintaining high quality and long life. The one piece design is the choice for general applications.

ALL STEEL MODELS

- **BOLT ISOLATION DESIGN FOR LONGER LIFE**
- **IMPACTING IN BOTH UP & DOWN STROKE**

VIBCO's steel units can take more abuse, operate longer with minimal lubrication, and have a longer life expectancy than the one piece design units. The all steel units should be used in continuous duty applications and where long life and high reliability is a must.

MODEL 50 & 55 STANDARD IMPACT PISTON VIBRATORS:

Most popular piston series because its high impact, linear force and efficient energy transfer assures the flow of materials through bins, chutes, weigh batchers, compacts powdered and viscous materials in containers and forms; activates screens and precipitators. Successfully used in thousands of applications in mining, chemical, plastics, concrete products, foundry, steel and paper industries.

EXHAUST SILENCER & DUSTPROOFER: For Silent & Long Stroke Silent Units. A useful accessory that both reduces exhaust noise and protects working parts of vibrator in dusty atmospheres for lower maintenance and prolonged life. Threaded exhaust is ideal for closed sanitary system.

MODEL 50-S & 55-S SILENT OPERATING PISTON

VIBRATORS: In areas where noise is objectionable VIBCO Model S should be used. Quiet because piston impact is eliminated by cushion of air at both ends. High thrust oscillatory action permits operation even at low air pressures. When Silent models are used in place of Impact units use the next larger size.

MODEL 50-L LONG STROKE PISTON VIBRATORS: The problem solvers! Extra-long bodies for high amplitude, high force and lower frequency vibration. The larger shake is best for moving fluffy, low density and wet or sticky materials. Especially suited for packaging and screening. Available in 2" and 3" piston sizes. Model 50-LS - Air-Cushioned Model. Silent models also available with silencer & dustproof.

MODEL 50-2EP EXTENDED PISTON VIBRATORS: Extended Piston has a 5/8" stroke and threaded extension for attaching rods or bumpers. The air cushioned piston operates quietly at 2400 VPM, 60 PSI & 8 CFM. Ideal for use on portable tote or hoppers.

MODEL 50-LI HIGH ENERGY IMPACTORS: All are available in 1-1/4, 2 & 3" piston sizes. The piston impact is adjustable by regulating and controlling the air pressure through a timer and solenoid. Piston impacts can be regulated. The LI-impactors are low in operating cost and used in continuous production applications to move material uninterrupted in bins, hoppers, chutes and feeders. Ask for Li-Bulletin for more technical data. Requires lubricated air.

All pneumatic piston vibrators require lubricated air for proper operation and long life. On 1-1/2" dia. and larger pistons on vertical mount, a spring is required for proper starting.

Piston Vibrators

TECHNICAL DATA

MODEL 50, 55

Piston Size	40 PSI		60 PSI		80 PSI		Contents in Bin
	CFM	VPM	CFM	VPM	CFM	VPM	
1S	3.5	3900	4	5400	5	6500	100-200
1	3.5	6500	4	9000	5	11000	200-400
1-1/4S	5	2400	7	3300	9	4200	200-400
1-1/4	5	4000	7	5500	9	7000	400-1000
1-1/2S	6.5	1700	9	2400	11	3200	400-1000
1-1/2	6.5	2800	9	4000	11	5200	1000-4000
2S	7.5	1950	12	2400	15	3000	1000-4000
2	7.5	3200	12	4000	15	5000	4000-10000
2LS	17	950	26	1200	31	1500	4000-10000
2L	17	1600	26	2000	31	2400	8000-20000
3S	18	1650	25	1950	30	2300	8000-20000
3	18	2700	25	3200	30	3800	10000-30000
3LS	31	800	42	900	51	1000	10000-30000
3L	31	1350	42	1500	51	1700	20000-70000
4S	33	1000	41	1200	50	1400	20000-70000
4	33	1400	41	1600	50	2000	Over - 70000

* The following data is furnished as a guide in estimating the sizes of piston vibrators for standard hopper shapes containing dry, granular materials of 50 lbs/cu. ft. minimum bulk density. For other sizes and densities, contact VIBCO.

Note: Dimensions and data subject to change without notice.

Data shown is average test data & will vary with cleanliness of the compressed air, lubrication and stiffness of application.

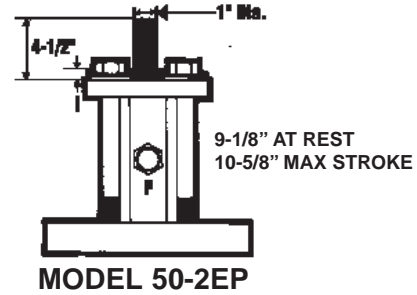
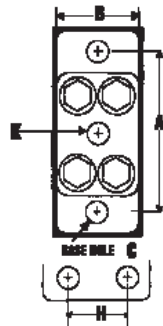
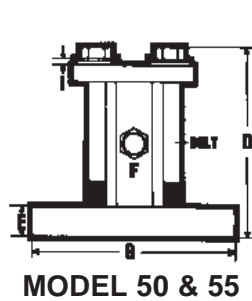

DIMENSIONS

Model	inch A	mm	inch B	mm	inch C**	mm	inch D	mm	inch E	mm	inch F	mm	inch G	mm	inch H	mm	inch I	mm	inch K	mm
50-1"	3 1/2	89	2	51	1/2	13	4 9/16	116	5/8	16	1/8 - NPT	4 1/2	114	-	-	3/16	5	-	-	-
50-1 1/4"	4 1/2	114	2 1/2	64	1/2	13	6 1/2	165	7/8	22	1/4 - NPT	6	152	-	-	7/32	6	-	-	-
50-1 1/2"	6*	152	3	76	3/4	19	7 15/16	202	7/8	22	1/4 - NPT	7 1/2	191	-	-	9/32	7	-	-	-
50-2"	6*	152	3 1/2	89	3/4	19	7 15/16	202	7/8	22	1/4 - NPT	9	229	-	-	1/4	6	-	-	-
50-2L"	6*	152	3 1/2	89	3/4	19	9 1/16	240	7/8	22	1/4 - NPT	9	229	-	-	1/4	6	-	-	-
50-2EP"	6*	152	3 1/2	89	3/4	19	***	***	7/8	22	3/8 - NPT	9	229	-	-	1/4	6	-	-	-
50-3"	8 7/16	214	4 1/2	114	3/4	19	10 1/2	267	1	25	1/2 - NPT	10 1/2	267	2 1/2	64	5/16	8	-	-	-
50-3L"	8 7/16	214	4 1/2	114	3/4	19	13 1/2	343	1	25	1/2 - NPT	10 1/2	267	2 1/2	64	5/16	8	-	-	-
50-4"	8 7/16	214	5 1/2	140	1	25	11 1/8	295	1	25	1/2 - NPT	10 1/2	267	2 1/2	64	3/4	19	-	-	-
55-1"	3 1/2	89	2	51	1/2	13	3 3/8	98	5/8	16	1/4 - NPT	4 1/2	114	-	-	-	-	-	-	-
55-1 1/4"	4 1/2	114	2 1/2	64	1/2	13	5 5/8	143	7/8	22	1/4 - NPT	6	152	-	-	-	-	-	-	-
55-1 1/2"	7 1/2****	191	3 1/2	89	5/8	16	7 1/4	184	1 1/8	29	1/4 - NPT	9	229	-	-	-	-	-	-	-
55-2"	7 1/2****	191	3 9/16	97	5/8	16	7 1/4	184	1 1/8	29	1/4 - NPT	9	229	-	-	-	-	-	-	-
55-3"	7 3/4	197	5	127	7/8	22	9 1/16	240	1 1/8	29	3/8 - NPT	10 1/2	267	3/4	83	-	-	-	-	-
LI-1 1/4"	4 1/2	114	2 1/2	64	1/2	13	8 7/16	217	7/8	22	3/8 - NPT	6	152	-	-	7/32	6	3/8 - NPT	-	-
LI-2"	6*	152	3 1/2	89	3/4	19	8 7/8	225	7/8	22	1/2 - NPT	9	229	-	-	1/4	6	1/2 - NPT	-	-
LI-3"	8 7/16	214	4 1/2	114	3/4	19	13 1/2	343	1	25	1/2 - NPT	10 1/2	267	2 1/2	64	5/16	8	1/2 - NPT	-	-

*Also available with 7-1/2". **Bolt Size ***See 50-2EP Diagram Note: Dimensions and data subject to change without notice.

****Will also fit 6" center hole dimensions (see Dimension A)



Pneumatic End Mounted

“BIG RED”



END TAPPED



END MOUNTED

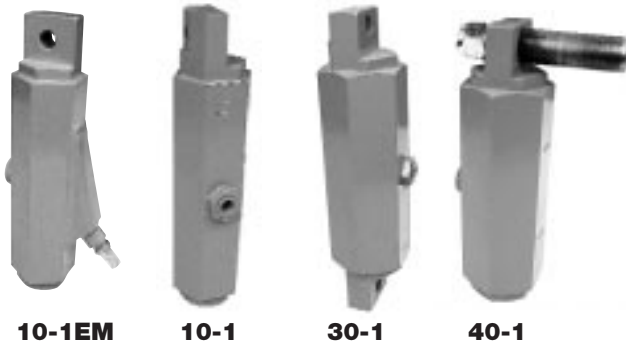

WEDGE HEAD

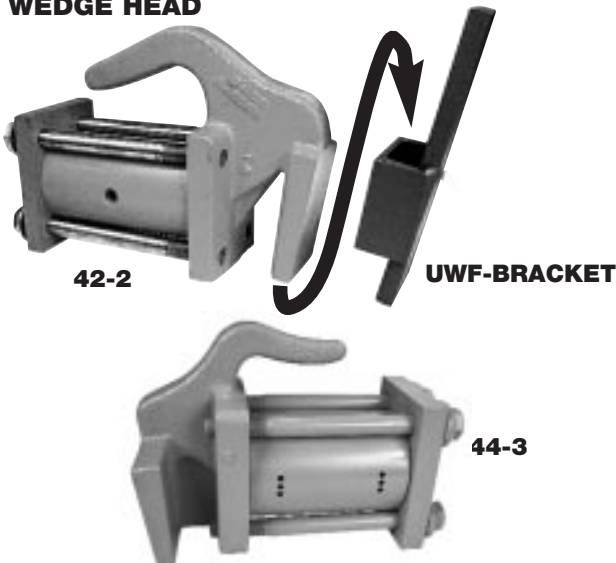

MODEL 80 END MOUNTED PISTON VIBRATOR - “BIG RED”:

The new revolutionary lightweight all steel design makes it the most inexpensive unit for the big bin or hopper job, without sacrificing the quality of the more expensive flange mounted units. The single bolt attachment makes them easy and fast to install. The “BIG RED” is supplied either with a silent (air cushioned) piston or the more powerful impacting (piston hitting end cap) standard unit.

O-rings cover the air exhaust holes keeping dust and dirt out of the piston chamber avoiding scoring and damage to piston and cylinder walls and allowing the units to operate in the worst environments. There are four basic models with piston sizes of 1”, 1-1/4”, 1-1/2” and 2”. For smaller sizes see Model 70. The eyebolt on top for a safety chain can be removed for other attachments.

MODEL 70 END TAPPED VIBRATOR: End tapped with inch or millimeter thread for attaching to threaded rod or stud. Model 70 can be supplied in many variations; silent (air cushioned) or impacting (piston hitting end cap) with exhaust port for attaching a muffler or air hose to lead off exhausting air. The all steel construction assures long life. Model 70 is an inexpensive solution for moving material in small bins and hoppers as well as screens and small feeders. Force and frequency will vary with air pressure. To order specify inch or millimeter thread; S - for Silent Units and EM - if Exhaust Manifold is required.

MODEL 10 END MOUNTED PISTON VIBRATOR: Single attaching head is the basic unit for foundry match plate applications. Available in 5/8, 3/4, 1, 1-1/4, & 1-1/2” piston diameter.

MODEL 30 END MOUNTED PISTON VIBRATOR: Double attaching head for core box machines and applications needing more vibration transfer.

MODEL 40 END MOUNTED PISTON VIBRATOR: Stud head vibrator ideal for easy movability on small concrete forms or bins.

MODEL 42 WEDGE HEAD VIBRATOR: VIBCO Wedge Head Portable Vibrators - High impact vibratory energy facilitates the placement of concrete within intricately shaped forms. Available in 2” piston size. Uses UWF-Female brackets.

MODEL 44 WEDGE HEAD VIBRATOR: Railroad carshakers have wedge bracket to fit railroad car’s female “dove-tail” bracket. Available in 3”. See page 41 and 42 for additional Railroad Carshakers.

All pneumatic piston vibrators require lubricated air for proper operation and long life.

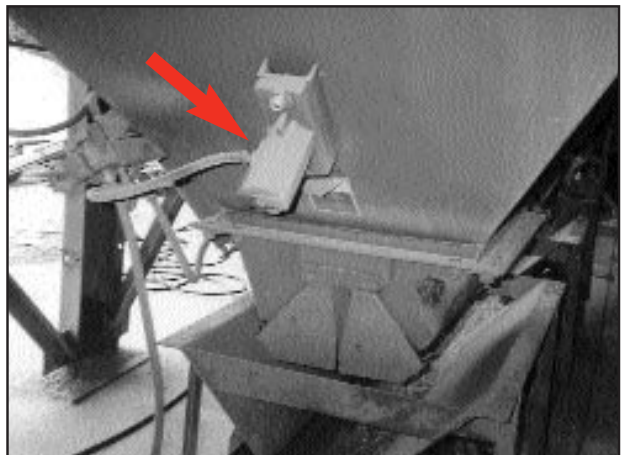

Piston Vibrators

TECHNICAL DATA

MODEL 10, 30, 40, 42, 44, 70, 80

Piston Size	40 PSI (3 Bar)		60 PSI (4 Bar)		80 PSI (5 Bar)		*Contents in Bin
	CFM	VPM	CFM	VPM	CFM	VPM	
5/8	2.5	9500	3	12000	4.5	14500	Up to 100 lbs.
3/4	3	7500	3.5	10500	5	13000	100-200
1S	3.5	3900	4	5400	5	6600	100-200
1	3.5	6500	4	9000	5	11000	200-400
1 1/4S	5	2400	7	3300	9	4200	200-400
1 1/4	5	4000	7	5500	9	7000	400-1000
1 1/2S	6.5	1700	9	2400	11	3200	400-1000
1 1/2	6.5	2800	9	4000	11	5200	1000-4000
2S	7.5	1950	12	2400	15	3000	1000-4000
2	7.5	3200	12	4000	15	5000	4000-10000
3S	18	1650	25	1950	30	2300	8000-20000
3	18	2700	25	3200	30	3800	10000-30000

*The following data is furnished as a guide in estimating the sizes of piston vibrators for standard hopper shapes containing dry, granular materials of 50 lbs/cu. ft. minimum bulk density. For other sizes and densities, contact VIBCO.

Note: Dimensions and data subject to change without notice.

Data shown is average test data & will vary with cleanliness of the compressed air, lubrication and stiffness of application.

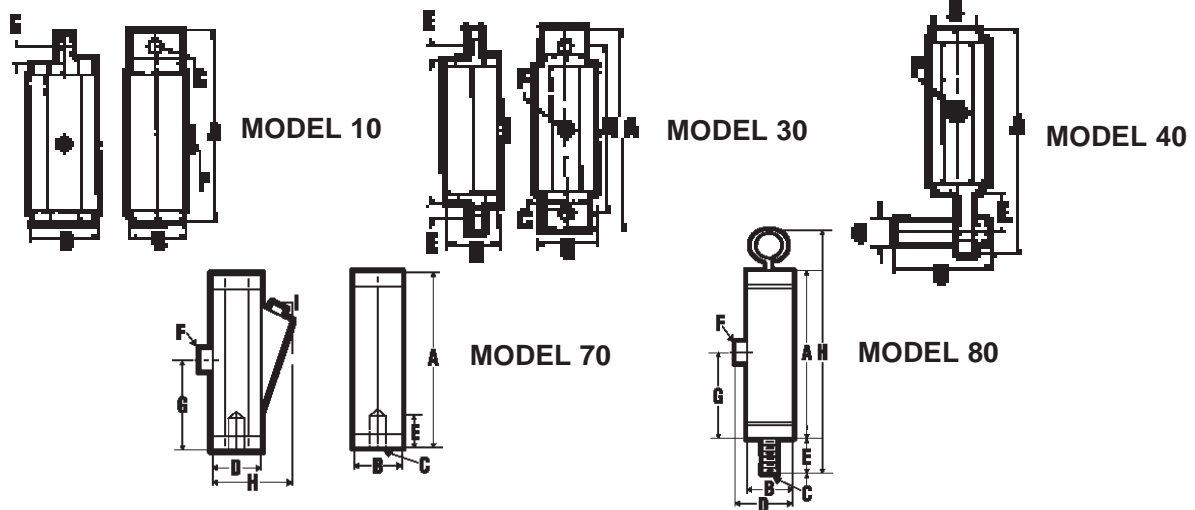

DIMENSIONS

MODEL	A Inch/mm	B Inch/mm	C Inch/mm	D Inch/mm	E Inch/mm	F Inch/mm	G Inch/mm	H* Inch/mm	I Inch/mm
80 - 1	4 1/2 114	1 1/2 38	1/2-20	2 1/8 54	1 25	1/8 - NPT	2 1/8 64	7 178	-
80 - 1-1/4	5 1/8 130	1 1/4 44	5/8-18	2 1/8 54	1 15/16 33	1/4 - NPT	2 3/16 71	9 9/16 237	-
80 - 1-1/2	6 152	2 51	5/8-18	2 1/2 64	1 7/16 33	1/4 - NPT	4 1/8 105	10 9/16 259	-
80 - 2	8 203	2 1/2 64	7/8-14	3 1/16 78	1 3/8 35	1/4 - NPT	4 1/8 105	11 1/2 292	-
70 - 5/8	4 3/4 120	1 1/4 32	5/16-24 M8x1.25	*1 15/16 33	5/8 16	1/8 - NPT	2 3/8 60	2 3/8 60	1/4 - NPT
70 - 3/4	4 3/4 120	1 5/8 41	3/8-24 M10x1.5	1 3/8 41	5/8 16	1/8 - NPT	2 3/8 60	2 3/8 67	1/4 - NPT
70 - 1	4 3/4 120	1 7/8 48	1/2-20 M12x1.75	1 7/8 48	5/8 16	1/8 - NPT	2 3/8 60	2 3/8 74	1/4 - NPT
70 - 1-1/4	8 203	2 5/16 59	1/2-20 M12x1.75	2 5/16 59	5/8 16	1/4 - NPT	4 101	3 1/2 89	1/4 - NPT
40 - 1	6 9/16 157	1 7/8 48	1/2 13	2 3/4 70	7/16 11	1/8 - NPT	1 1/2 12	-	-
40 - 1-1/4	9 1/2 241	2 5/16 59	1 25	4 3/4 121	3/4 19	1/4 - NPT	1 25	-	-
30 - 5/8	6 9/16 160	1 1/4 32	5/16 8	1 15/16 33	1/2 12	1/8 - NPT	5 1/16 136	5 7/16 136	-
30 - 3/4	6 9/16 160	1 5/8 41	3/8 10	1 15/16 33	1/2 12	1/8 - NPT	5 1/16 136	5 7/16 136	-
30 - 1	6 9/16 167	1 7/8 48	3/8 10	1 7/8 48	1 12	1/8 - NPT	5 1/16 136	6 3/8 162	-
30 - 1-1/4	10 1/2 267	2 5/16 59	1/2 12	2 5/16 59	1 17/16 17	1/4 - NPT	9 1/8 228	9 1/2 232	-
30 - 1-1/2	11 3/8 289	2 7/8 73	5/8 16	2 5/16 73	7/8 22	1/4 - NPT	9 1/2 241	9 1/2 241	-
10 - 5/8	5 1/2 140	1 1/4 38	5/16 8	1 15/16 33	1/2 12	1/8 - NPT	-	-	-
10 - 3/4	5 1/2 140	1 5/8 41	3/8 10	1 3/8 35	1/2 12	1/8 - NPT	-	-	-
10 - 1	5 5/8 143	1 7/8 48	3/8 10	1 7/8 48	1/2 12	1/8 - NPT	-	-	-
10 - 1-1/4	9 1/4 235	2 5/16 59	1/2 12	2 5/16 59	1 15/16 18	1/4 - NPT	-	-	-
10 - 1-1/2	9 11/16 246	2 1/2 64	5/8 16	2 5/16 75	7/8 22	1/4 - NPT	-	-	-

*For EM Models. Note: Dimensions and data subject to change without notice.